

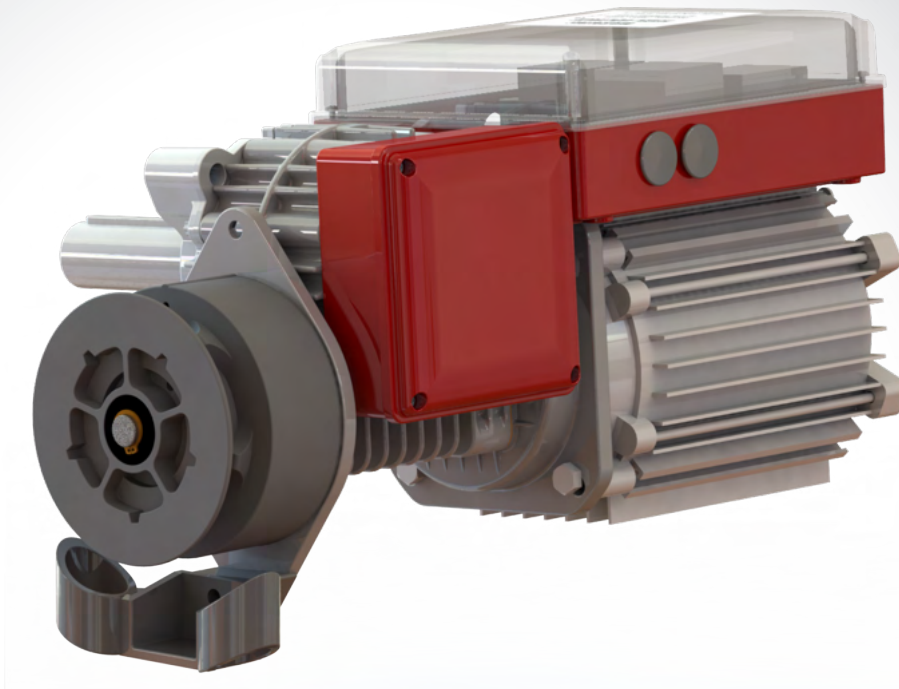

INSTRUCTION MANUAL



E-Drive

- MH Series
- ML Series
- Compatible with Security+ 2.0[®] accessories
- Compatible with Grifco myQ Internet Gateway

Chamberlain Australia Pty Ltd
Suite G.02, City Views Business Park,
65 Epping Rd
Macquarie Park NSW 2113

Ph: 1800 GRIFCO
www.grifco.com.au

Ref: D-M-RDO-006_D
25-05-2026

Chamberlain New Zealand Ltd
17B Arrenway Drive, Rosedale 0623
Auckland
Ph: 0800 653 667
www.grifco.co.nz



GRIFCO[®]

SAFETY INSTRUCTIONS



WARNING: THESE ARE IMPORTANT SAFETY INSTRUCTIONS.
FOLLOW ALL INSTRUCTIONS AS INCORRECT INSTALLATION CAN LEAD TO SEVERE INJURY OR DEATH
SAVE these instructions

This commercial roller door operator has been designed and tested to offer safe service provided it is installed, operated, maintained and tested in strict accordance with the instructions and warnings contained in this manual.



WARNING

Mechanical

When you see this Safety Symbol and Signal Words on the following pages, they will alert you to the possibility of serious injury or death if you do not comply with the warnings that accompany them. The hazard may come from something mechanical.

- Keep commercial door balanced. Sticking or binding doors must be repaired. Commercial doors, door springs, pulleys, brackets and their hardware are under extreme tension and can cause serious personal injury. Do not attempt to loosen, move or adjust them. Call for commercial door service.
- Do not wear rings, watches or loose clothing while installing or servicing a commercial door operator.
- To avoid serious personal injury from entanglement, remove all ropes connected to the commercial door before installing the door operator.
- After the installation a final test of the full function of the system and the full function of the safety devices must be done.
- When operating a biased-off switch, make sure that other persons are kept away.
- The operator cannot be used with a driven part incorporating a wicket door (unless the operator cannot be operated with the wicket door open).
- Operator may become hot during operation. Appropriate clearance and/or shielding should be supplied by the installer to ensure any cabling, wiring and/or other items cannot come in contact with the operator. If temperature rise exceeds 50°C all fixed wiring insulation must be protected, for example, by insulating sleeving having an appropriate temperature rating.
- Do not allow children to play with operator wall controls or remote controls. Keep remote controls away from children.
- Permanently fasten all supplied labels adjacent to the wall control as a convenient reference and reminder of safe operating procedures.
- Disengage all existing commercial door locks to avoid damage to commercial door. Install the wall control (or any additional push buttons) in a location where the commercial door is visible during operation. Do not allow children to operate push button(s) or remote transmitter(s). Serious personal injury from a closing commercial door may result from misuse of the operator.
- Activate operator only when the door is in full view, free of obstructions and operator is properly adjusted. No one should enter or leave the building while the door is in motion.
- The actuating member of a biased-off switch is to be located within direct sight of the door but away from moving parts. Unless it is key operated, it is to be installed at a minimum height of 1500mm and not accessible to the public.
- Make sure that people who install, maintain or operate the door follow these instructions. Keep these instructions in a safe place so that you can refer to them quickly when you need to.
- This appliance is not intended for use by persons (including children) with reduced physical, sensory or mental capabilities, or lack of experience and knowledge, unless they have been given supervision or instruction concerning use of the appliance by a person responsible for their safety. Children should be supervised to ensure that they do not play with the appliance.
- Use the operator for its intended purpose. The operator is designed to operate spring-balanced roller doors and roller shutters.
- Automatic Drive - Keep away from the area of the door as it may operate unexpectedly.
- Ensure that entrapment when operating the door in the open direction is avoided.



WARNING

Electrical

When you see this Safety Symbol and Signal Words on the following pages, they will alert you to the possibility of serious injury or death if you do not comply with the warnings that accompany them. The hazard may come from electric shock.

- If the supply cord is damaged, it must be replaced by the manufacturer, its service agent or similarly qualified persons in order to avoid a hazard.
- Installation and wiring must be in compliance with your local building and electrical codes. Connect the power supply cord only to properly earthed mains.
- Moisture and water can destroy the electronic components. Make sure under all circumstances that water moisture or storage moisture cannot penetrate the electronics. The same applies for openings and cable entries.
- An electrician must disconnect electric power to the commercial door operator before making repairs or removing covers.

CAUTION

When you see this Signal Word on the following pages, it will alert you to the possibility of damage to your commercial door and/or the commercial door operator if you do not comply with the cautionary statements that accompany it.

CONTENTS

SAFETY INSTRUCTIONS	2
INTRODUCTION	3-4
MAJOR COMPONENTS	4
MAIN CONTROL BOARD (MCB) LAYOUT.....	5
WIRE STRIPPING	6
PLANNING	7
INSTALLATION	8-12
MOUNTING THE UNIT	8-9
INSTALLING HAND CHAIN.....	10
CONNECTING POWER.....	11
CONTROLLER.....	12
ACEM.....	12
SET UP AND ADJUSTMENT	13-14
CHECKING POWER	13
DOOR DIRECTION	13
CHANGING DOOR DIRECTION.....	13
SETTING LIMITS.....	14
OPTIONAL THIRD LIMIT.....	14
OPERATION	14
DOOR BEHAVIOUR.....	15
DOOR BEHAVIOUR MODES.....	15
SETTING DOOR BEHAVIOUR	15
ENTRAPMENT PROTECTION AND ACCESSORIES INPUTS.....	16-17
INSTALLING ENTRAPMENT PROTECTION DEVICES	16
ADDITIONAL SWITCHGEAR/ACCESSORIES.....	16
TOGGLE INPUT (2 WIRE).....	17
ACCESSORIES	18
AUTO CLOSE AND WIRELESS ACCESSORY SET UP (INCLUDING MYQ GATEWAY).....	19-20
MAINTENANCE	21
TROUBLESHOOTING	22-23
CHAMBERLAIN LIMITED WARRANTY	24

INTRODUCTION

E-DRIVE COMPONENTS

Your standard E-Drive includes:

- Opener
- Mounting bolts
- Controller (containing controller cable)

**Appearance may vary with different motor, gearbox and controller configurations*

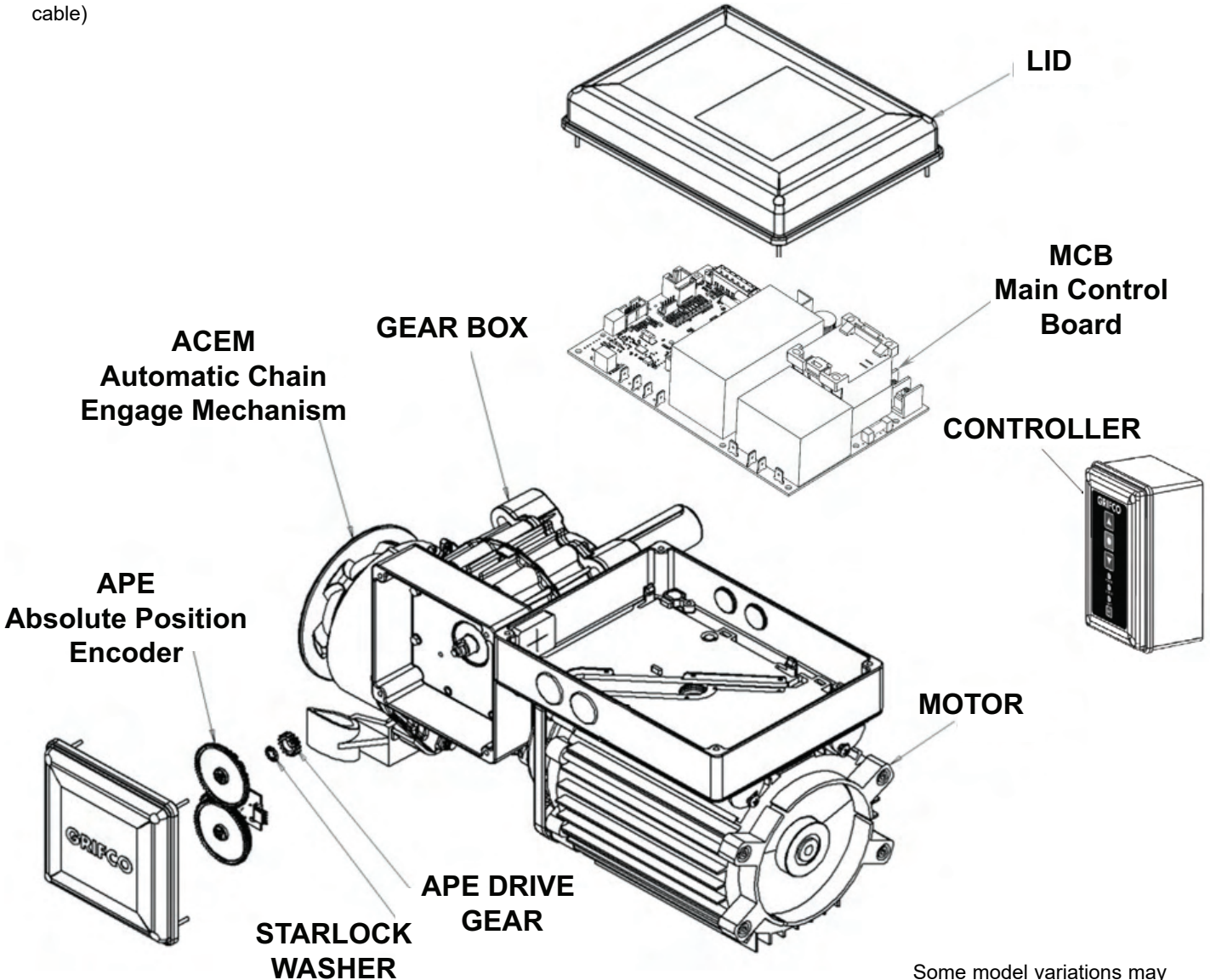

Some model variations may include optional extras such as a mounting plate, sprockets, chain, beams and transmitter.



WARNING MECHANICAL

Make sure that people who install, maintain or operate the door follow these instructions. It is advised that the instruction be kept in a safe place so that you can refer to them quickly when you need to.



WARNING MECHANICAL

Please remove any locks fitted to the door before operation in order to prevent damage to the door.

MAIN CONTROL BOARD (MCB)

MAIN CONTROL BOARD (MCB)

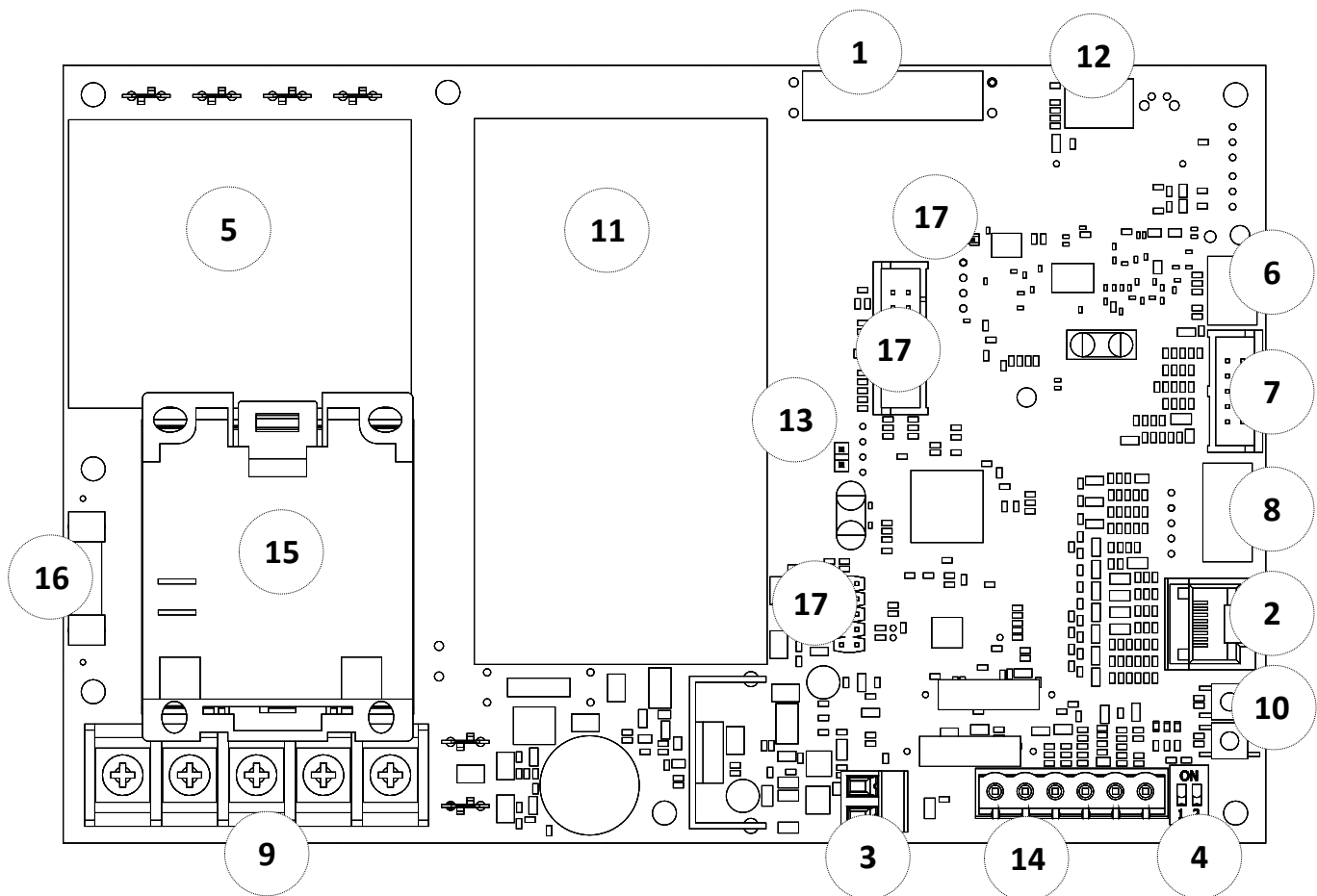

1.	Motor terminals	10.	'Learn' (LRN) and 'Reset' (RST) buttons
2.	Wall Controller connection	11.	Mechanically interlocked contactors
3.	Accessory Power	12.	TEMP or Safety cut-out terminals (N/C)
4.	Door behaviour	13.	Radio lock (jumper fitted to lock)
5.	Transformer	14.	Entrapment protection device inputs
6.	Toggle input	15.	Safety isolator contactor
7.	Expansion board input	16.	Replaceable transformer fuse
8.	APE connection	17.	DO NOT USE (for manufacturer use only)
9.	Power supply terminals		

Note: MCB Layout may vary depending on build type.

WIRE STRIPPING

When stripping cable during the eDrive installation, the cables MUST BE stripped outside the MCB (Main Control Board) enclosure. Failure to do so will destroy the MCB as wire cut offs will cause a short circuit. Such events are NOT covered by the GRIFCO warranty.

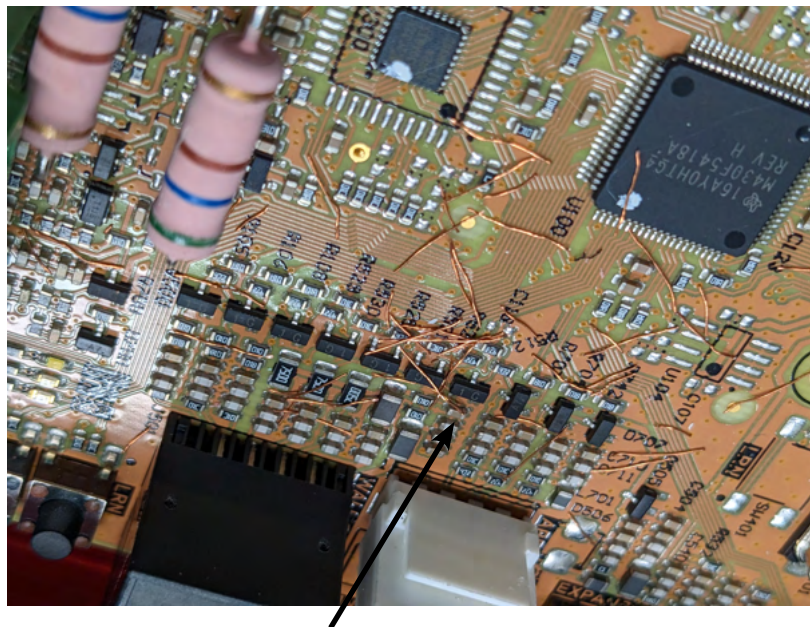

Wire off cuts will destroy the MCB

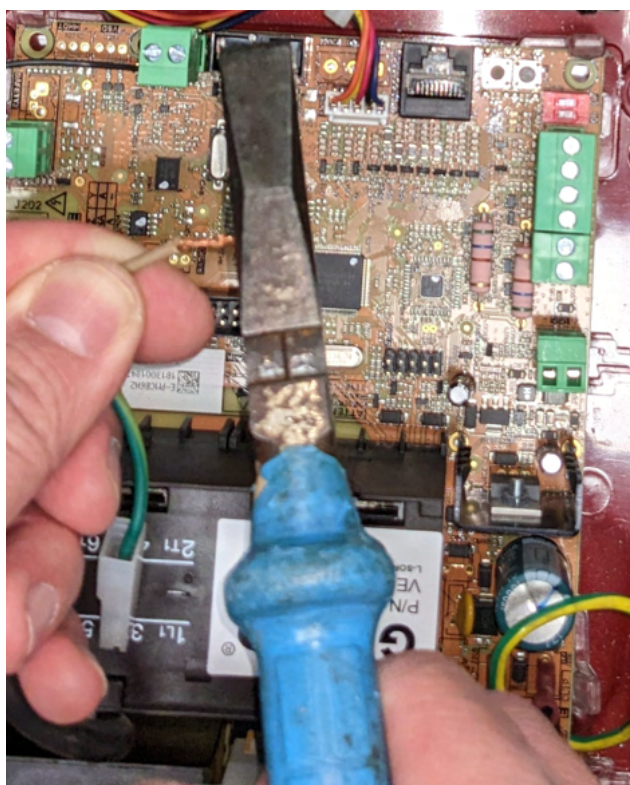

Incorrect

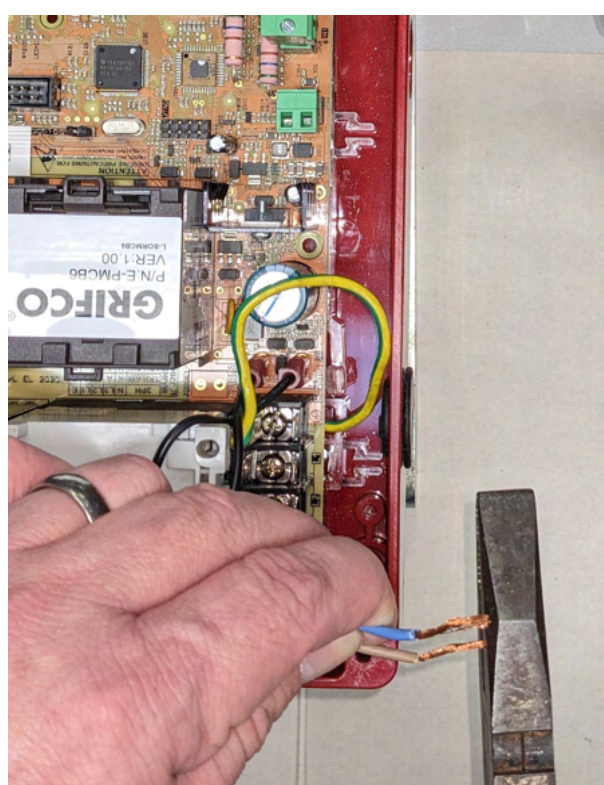

Correct

SPECIFICATIONS

Before installation, identify the type and dimensions of your commercial rolling door. A check of the application is recommended to ensure suitability of the opener model to the door.

The installer is required to check that the temperature range marked on the drive is suitable for the location.

Rated Voltage 230-240V, 50Hz (1 phase models) and 400-415V, 50Hz (3 phase models).

Opener Build	Rated Load (Nm)	Hp	Duty Rating (% / min)	Phase	Door size (m2)*	kW	Amp	Max Door Mass (KG)**
ML6053	47	0.5	10 / 6	3	18	0.55	1.6	270
ML6103	130	1.0	10 / 6	3	36	1.35	2.4	540
MH6103	80	1.0	30 / 18	3	30	0.99	2.0	450
ML6153	190	1.5	10 / 6	3	50	1.7	2.9	890
ML6051	67	0.5	10 / 6	1	18	0.8	3.5	270
ML6102	85	1.0	10 / 6	1	36	1.4	6.0	480
MH6102	73	1.0	30 / 18	1	30	0.84	4.4	450

NOTE: E-Drive openers are not recommended for use on residential garage doors.

* Door size is stated as a guide only. Refer to "max door mass" to assess drive suitability.

** Maximum door mass is:

- before spring balancing. Door must be spring balanced.
- based on at least 4:1 sprocket ratio, and curtain load with 200mm drum diameter.

If any conditions above are not met, some consideration should be given to increasing the sprocket ratio, or opener size. The opener should be installed on the most suitable side of the commercial door. Consider an In-Board Mounting Kit (P/N IBMK) if there is insufficient side room. Select the side that meets the requirements listed below.

- Must have minimum distance of 15mm between mounting plate and door drum sprocket
- Must have minimum distance of 10mm between APE housing and imposing structure
- Must have minimum overhead clearance of 150mm from the main control housing

NOTE: Before installing the opener, check that the commercial door is in good mechanical condition, correctly balanced and opens and closes properly.

Doors of Rigid Construction

When using a Grifco® E-Drive on commercial doors of 'rigid' construction (eg. continuous steel roller doors etc.), consider that the **limit confirmation** movement requires a 1/4 turn of the output shaft downward at the closed position (refer to page 13 for more information). Sufficient mechanical freedom must be provided at the closed position for this reason.

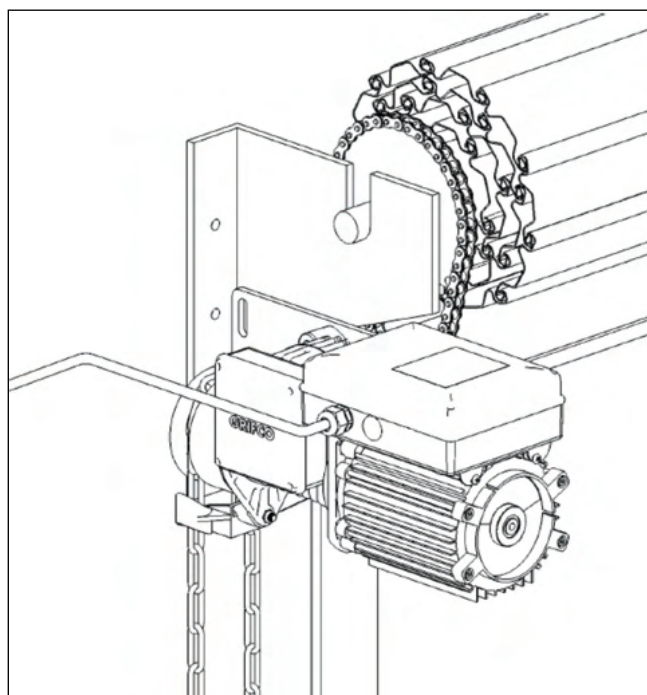

WARNING MECHANICAL

The door guides must be fitted with mechanical stops that prevent the bottom rail from passing through in the opening direction. The opener should stall if driven into the mechanical stops.

INSTALLATION

MOUNTING THE UNIT

The E-Drive is typically flag mounted below the door drum so that the opener shaft points toward the door opening and lies beneath the sprocket of the door drum. For mounting you will need to either secure the opener to the head plate of the roller door or roller shutter with prepared holes or slots, or use a mounting plate that will need fixing via a wall angle or similar existing structure.

Note: The E-Drive is not designed to be installed upside down. The chain guide must not be repositioned.

It is strongly recommended that a suitably rated lifting strap be used to raise the opener to a necessary height, shown right. A suitable lifting device should be connected to a secure support beam (or similar) above the door axle.

When assessing and selecting an appropriate mounting location, the following considerations should be made:

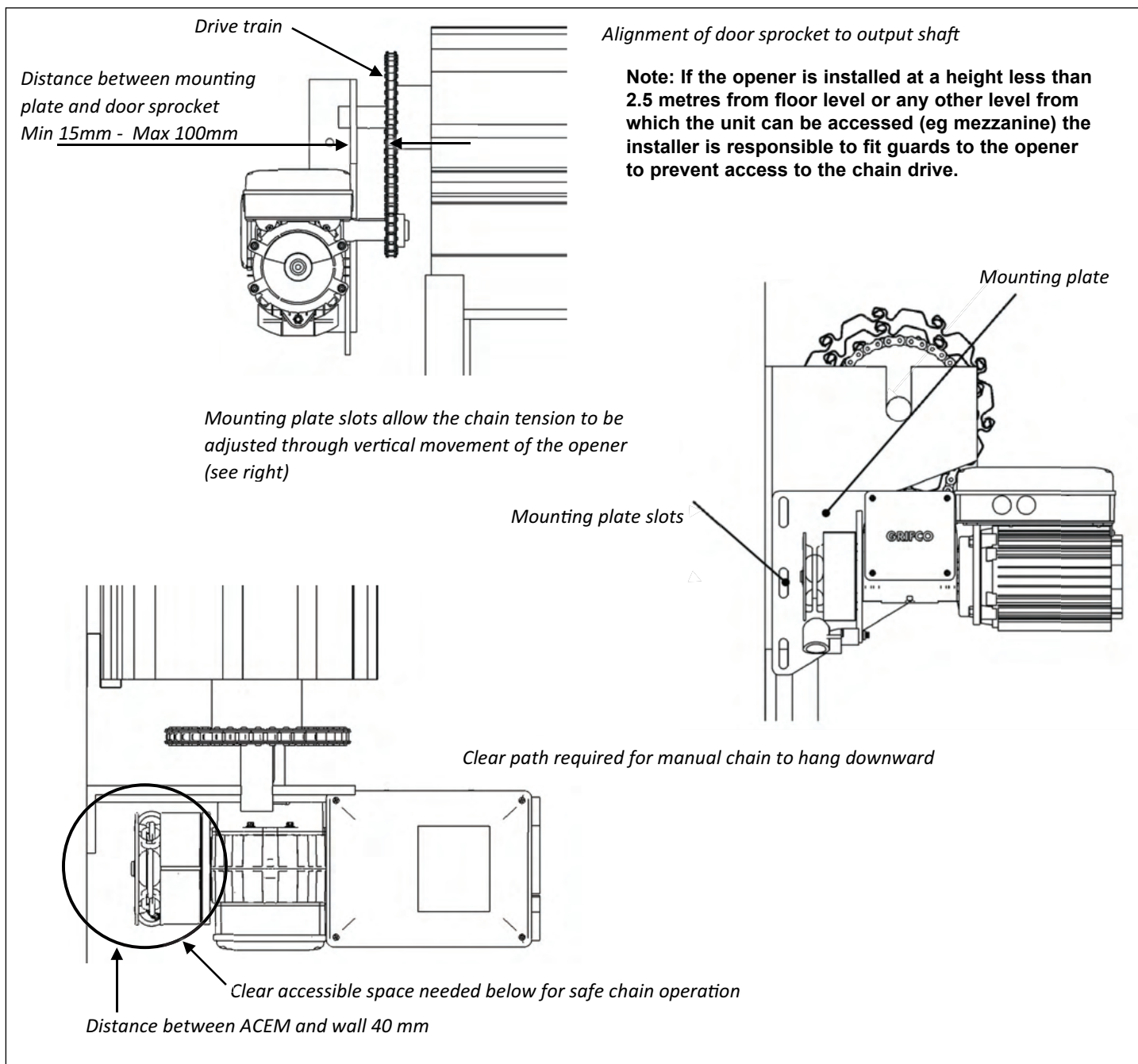
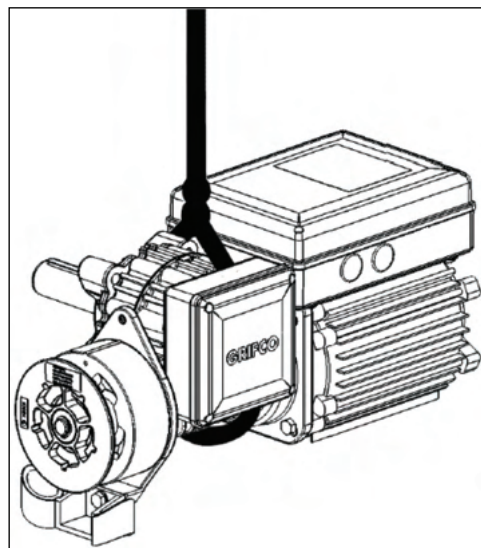

INSTALLATION

Slide room to imposing structures

The E-Drive APE housing is not a serviceable area and can be located within 10mm of an imposing structure without affecting installation. Where there is insufficient side room, consider using the opposite hand opener and mount inboard with a Grifco® Inboard Mounting Kit, P/N IBMK.

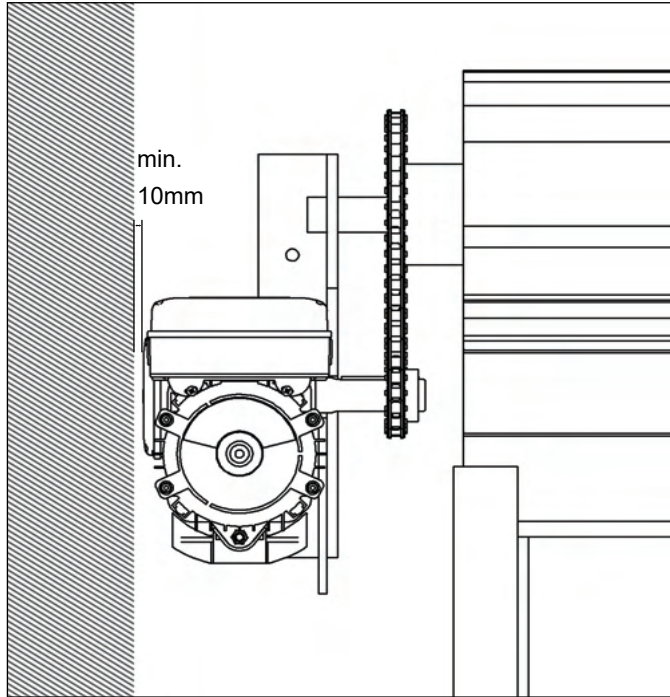

Limited head room

The E-Drive main control housing is a serviceable area and will need to be accessed by service personnel. Ensure the installation allows a minimum 150mm clearance.

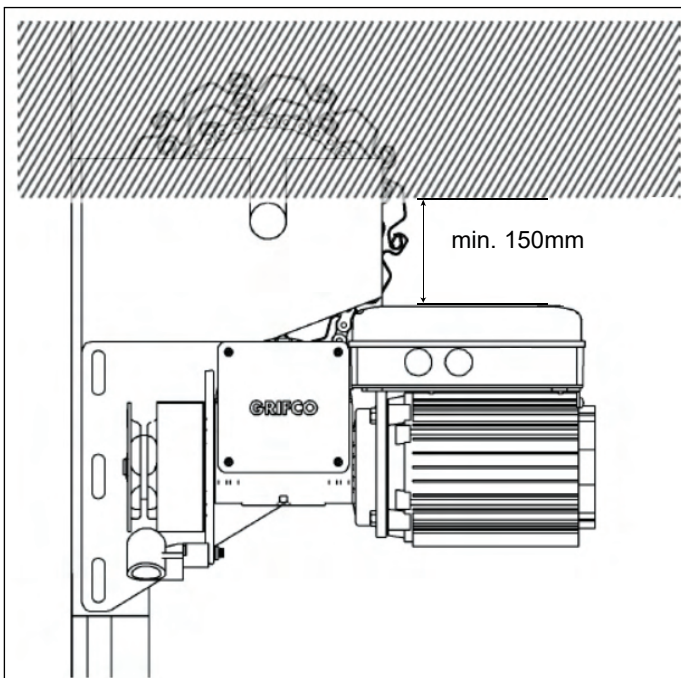

Location of Controller

Controller has 6 metres of cable with RJ45 ends ready to connect the E-Drive opener to the controller. E-Drive Controller Extension Kit (P/N EK01) is available if needed.

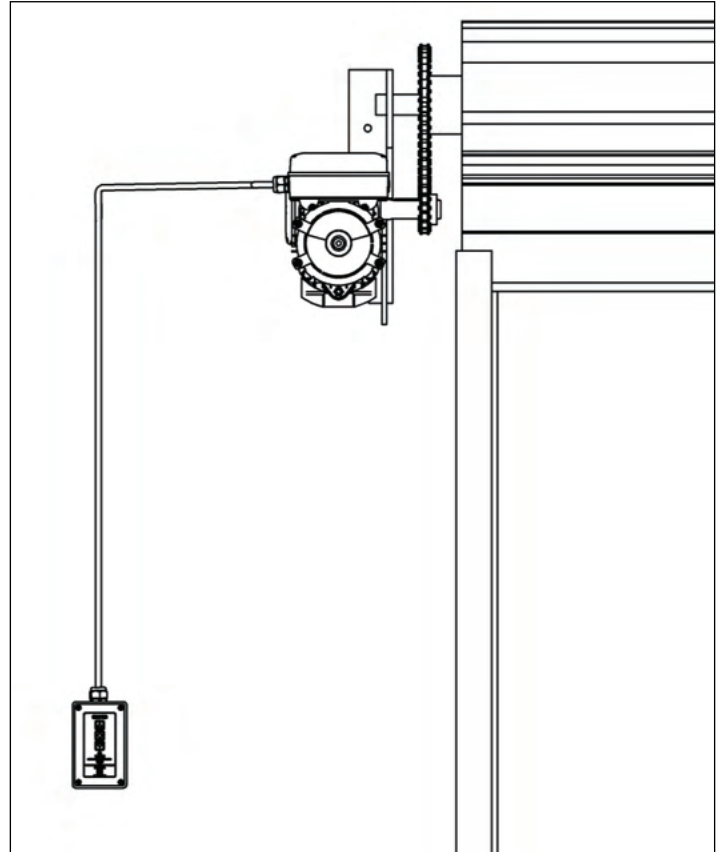

If there is insufficient head room above the E-Drive opener to allow servicing then a Grifco® Wall Mount Kit (P/N WMK2) or Grifco® Rotation Bracket (P/N RBK2) can be used to reposition the main control housing.



WARNING MECHANICAL

When securing the E-Drive opener with the 4 x M12 x 40mm long fasteners (based on an 8mm mounting plate) and spring washers provided, it is critical to ensure that the applied torque is between 80-90Nm. When mounting through thicker sections, ensure a minimum of 30mm of screw thread is engaged with the female thread. Use of incorrect fasteners or torque may cause serious product damage, personal injury or death. When fixing through a slotted plate, ensure that the slots are no wider than 13mm as a spring washer may not be adequate in outside diameter to support the hexagon head.

INSTALLATION

Installing Hand Chain

- Use 5mm long link chain only
- Ensure the mounting position allows the hand chain to hang free of obstructions
- Ensure hand chain is not twisted when re-making the join

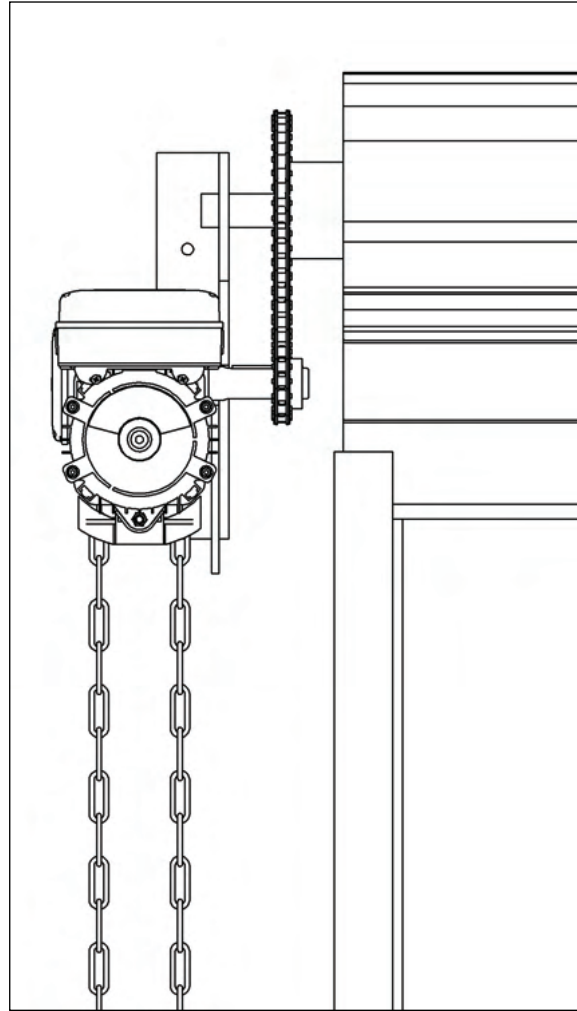
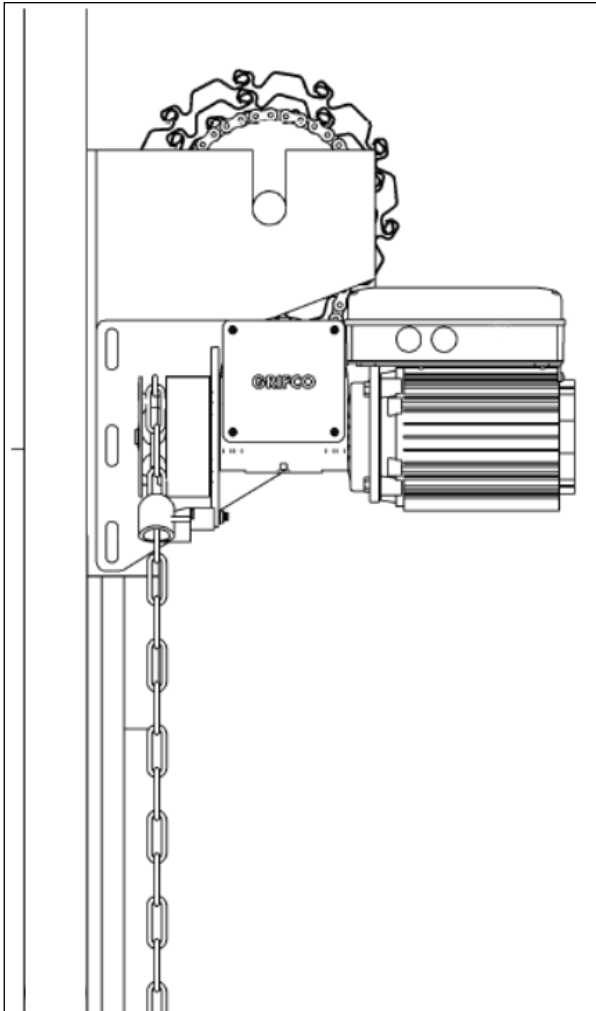

Automatic Chain Engagement Mechanism (ACEM)

The patented ACEM feature allows the use of the hand chain at all times when the motor is not in use and in the event of a power failure. Simply pull on the hand chain in either direction to operate the door manually.

Warning! Ensure power is isolated when using this feature.

The ACEM label (see right) must be fixed in close proximity to the controller e.g. on the door track.



CAUTION

Motor may become hot during operation. Appropriate clearance and/or shielding should be supplied by the in-staller to ensure any cabling, wiring and/or other items cannot come in contact with the motor. If temperature rise exceeds 50°C all cable wiring must be shrouded.

Fixed wiring insulation must be protected, for example, by insulating sleeving having an appropriate temperature rating.

INSTALLATION

WARNING **ELECTRICAL**

The E-Drive must:

- be connected via an approved electrical isolation device
- be connected via a suitable circuit breaker that disconnects all live conductors
- be connected in accordance with the wiring rules of the country in which it is installed
- not have control enclosures left open for extended periods (excess dust will void warranty)

Connecting power

If fitted with a plug and lead proceed to next page.

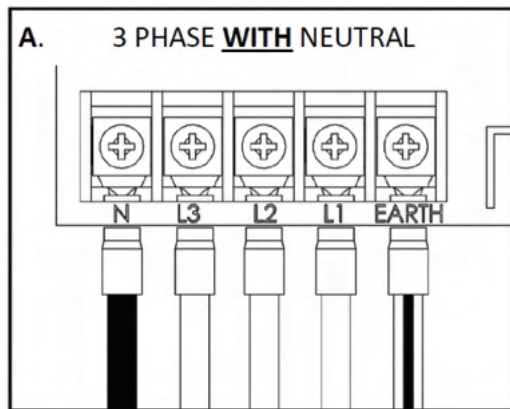

Supply connection for 3 phase builds with neutral

Models: ML6053, ML6103, MH6103 & ML6153

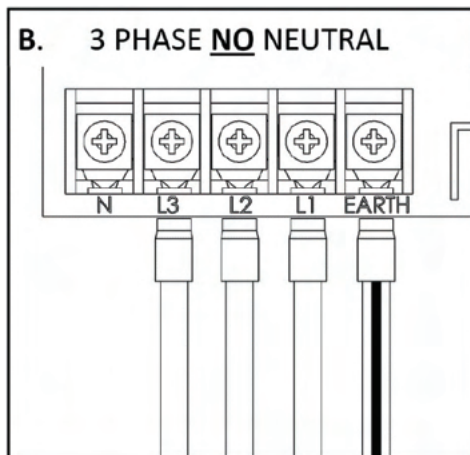
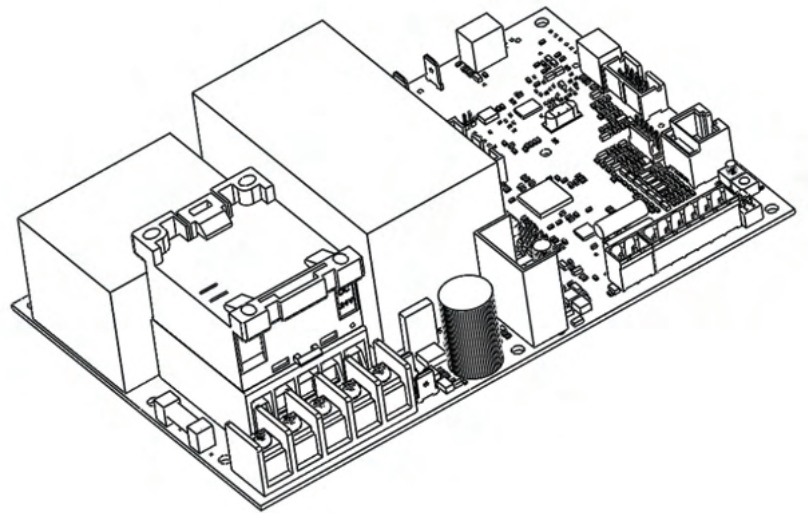

Supply connection for 3 phase builds without neutral

Models: ML6053N, ML6103N, MH6103N & ML6153N

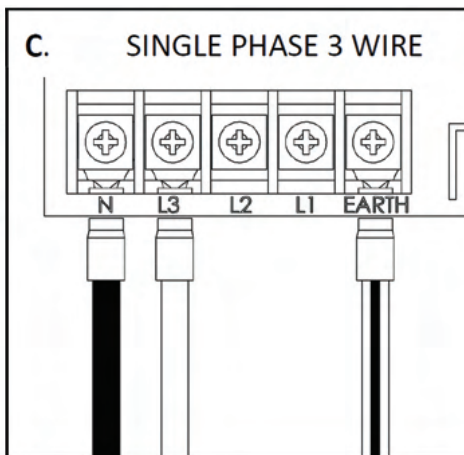

Supply connection for single phase builds with 3 wire configuration

Model: ML6051

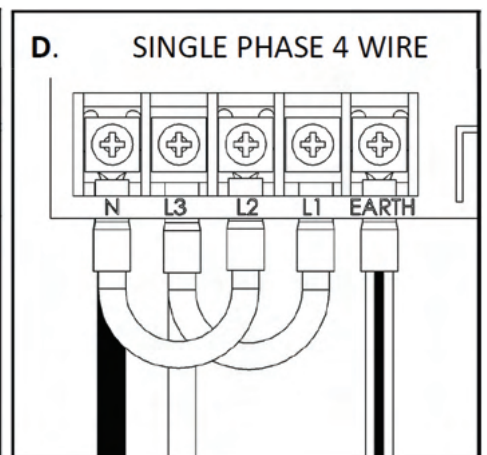

Supply connection for single phase builds with 4 wire configuration

Models: ML6102 & MH6102

It is recommended that 1.5mm²(max.) wire size is used to avoid unnecessary crowding and difficulty when making connections. Avoid lengthy cable ends that may cause undue pressure on delicate components.

NOTE:

- If the supply cord is damaged, it must be replaced by the manufacturer, its service agent, or a similarly qualified person in order to avoid a hazard.
- A disconnection device incorporated in the fixed wiring must be provided in accordance with the wiring rules of the country in which it is installed.

INSTALLATION

Controller

The E-Drive controller is the user interface for the opener. It consists of four buttons for control and setup, as well as three indicators to display the opener status.

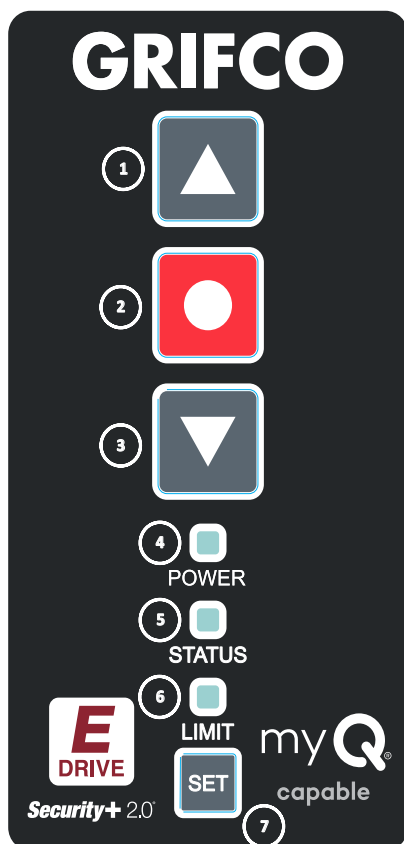

- 1. UP** Moves the door upwards
- 2. STOP** Stops the door
- 3. DOWN** Moves the door downwards
- 4. POWER** Shows when the unit is mains powered
- 5. STATUS** Shows the status of the unit (refer to 'Troubleshooting').
- 6. LIMIT** When lit indicates limits (or stopping positions) are not set, the door will only operate in SAFETY inch mode until limits are set (or reset).
- 7. SET** Used primarily to set limits and enter configuration modes.

Installing the Controller

The controller is connected to the MCB via a low voltage control cable provided within the controller enclosure. Using the conduit entries provided (also enclosed) run the cable through conduit. Be sure not to cut or damage the cable and therefore cause installation issues and void warranty.



WARNING MECHANICAL

Install the controller in a position where the door is visible. Failure to do so may result in serious injury or death to persons trapped beneath the door. Minimum mounting height is 1.5 metres from floor level.

CAUTION: Do not force the controller cable! Excess stretching and manipulation can cause cable failure. Plug ends must not be gripped with pliers.

To connect the controller to the E-Drive opener, identify the most appropriate entry of the MCB enclosure for your installation. Open the MCB enclosure and fit the conduit fitting, allowing enough cable to reach the controller (RJ45) socket. Place the opposing end of the controller cable through the conduit entry of the controller enclosure and pull through any excess cable. Plug the RJ45 end into the socket located within the controller assembly. Use the space provided within the controller enclosure to neatly coil any excess cable.

NOTE: If the supplied controller cable is **not** long enough for your installation, a Grifco® Controller Extension Kit is available (P/N ESK01).

SETUP AND ADJUSTMENT

Once the installation of the opener and controller is complete it is time to test the operation. Make sure the door is away from the ground or the top door stops (mid open position). This will prevent damage to the door in the event that the door direction is reversed in relation to the controller (see below changing door direction).

Checking power

Ensure the unit is powered by checking that the POWER ON indicator on the controller is lit. You should also notice that the *LIMIT* indicator (orange) is lit which signifies that there are no limits set.



CAUTION

On new installations, the orange limit light should be lit after initial power up. If not, DO NOT operate door unless in limit setting mode or serious damage or injury may occur.

Door direction

Check the direction of the door movement. If the direction of the door is incorrect, refer below to changing door direction.

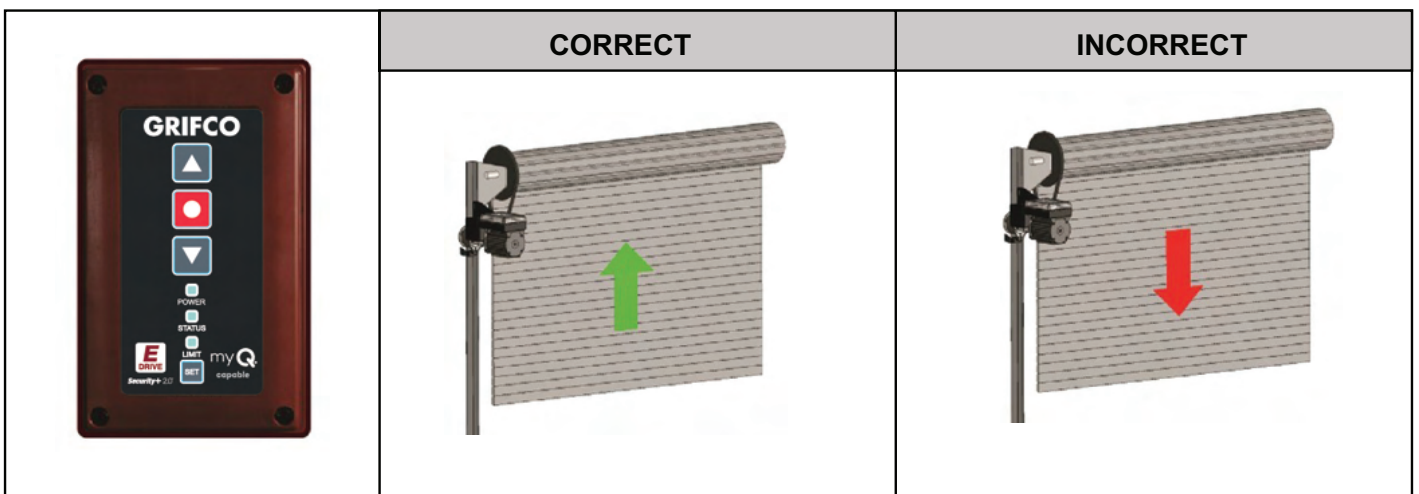

Changing door direction

To change the door direction first put the unit into 'limit setting mode' by following this

1. While holding STOP, press the SET button 3 times. The LIMIT indicator will start flashing signifying 'limit setting mode'
2. Press and hold STOP for 10 seconds until the LIMIT indicator flashes quickly.

The direction of the door movement will now be reversed.

The LIMIT indicator will remain flashing as the unit is still in limit setting mode. You can now set limits (go to step 2 on next page)

Or to exit, press STOP.



WARNING ELECTRICAL

When removing or replacing jumpers or expansion boards to or from the MCB mains power must be disconnected.



WARNING MECHANICAL

It is important to make sure the door always runs smoothly. Doors which stick or jam must be repaired immediately. Employ a qualified technician to repair the door, never attempt to repair it yourself.

READ CAREFULLY BEFORE SETTING LIMITS FOR RIGID DOORS

(NOT APPLICABLE TO ROLLER SHUTTERS)

Automated Positioning Routine

The E-Drive features a limit confirmation routine that occurs after a power outage upon the first push of the UP or DOWN buttons. By default, the routine will “jog” slightly downward in order to confirm door position before proceeding in the intended direction.

NOTE: For doors of rigid construction (e.g. bi-fold, vertical lift, sectional or continuous steel roller doors etc.) this routine should be changed so that the first “jog” movement is upward. To do so, proceed as follows:

- While holding STOP, press the SET button 3 times and CONTINUE to hold STOP for 20 seconds (or until the orange light goes solid).

RKML6051 models (1/2hp roller door openers) will confirm limits by jogging UPWARD first by default. To reverse the limit confirmation direction, proceed as above.

Setting Limits

While setting limits, ensure the upper limit is set NO CLOSER than 50mm from the top stops (or fully open position) of the door.

1. While holding STOP, press the SET button 3 times.

The LIMIT indicator will start flashing signifying ‘limit setting mode’

2. Use the DOWN button to drive the door to the desired CLOSED position.

The manual hand chain can be used to accurately position the door before pressing SET

3. Press the SET button to save this as the CLOSED position.

The LIMIT indicator will flash quickly then return flashing slowly

4. Use the UP button to drive the door to the desired OPENED position.

The manual hand chain can be used to accurately position the door before pressing set

5. Press SET again to save this as the OPENED position.

The LIMIT indicator will flash quickly then will go out

The Closed and Open limits should now be set. If at any time you need to exit ‘limit setting mode’ simply press the STOP button.

Once set, operate the door between limits 2 times to check they are suitable. If not, return to STEP 1.

Upon completion of the installation, turn power OFF, then back ON at the open and closed positions, and test proper operation accordingly. If required, refer to top of page to reverse the limit confirmation direction.



WARNING ELECTRICAL

Do not place hands or tools near the opener when power is on or when testing controls or safety devices.

Always disconnect power before servicing or adjusting the opener.



WARNING MECHANICAL

After the installation a final function test of the system along with a full function test of any connected safety devices must be done.

The E-Drive has the ability to set a third limit which is a handy option for high doors that rarely need to be fully opened. The third limit is a door position above the open limit position which can be accessed when needed. Having this upper stopping position allows a mid-height limit to be set as a first opening point, while a further press of the open button takes the door to a higher set position (not supported by myQ).

Setting a third limit

1. Follow the “Setting Limits” steps to set the Open and Closed limits
2. Position the door at the Open limit position
3. While holding the UP button, press the SET button 3 times.
The LIMIT indicator will flash
4. Press and hold the UP button until the door is in the desired extended open position
5. Press SET to save this as the extended open position.

The LIMIT indicator will quickly flash then go out

To access the third limit open the door to the first limit then press the UP button again.

DOOR BEHAVIOUR

Setting door behaviour

To set the door behaviour modes, adjust the DIP switches in the corner of the MCB shown.

DIP Switch 1 controls the latch option of the DOWN direction while DIP Switch 2 controls the latch option of the UP direction.

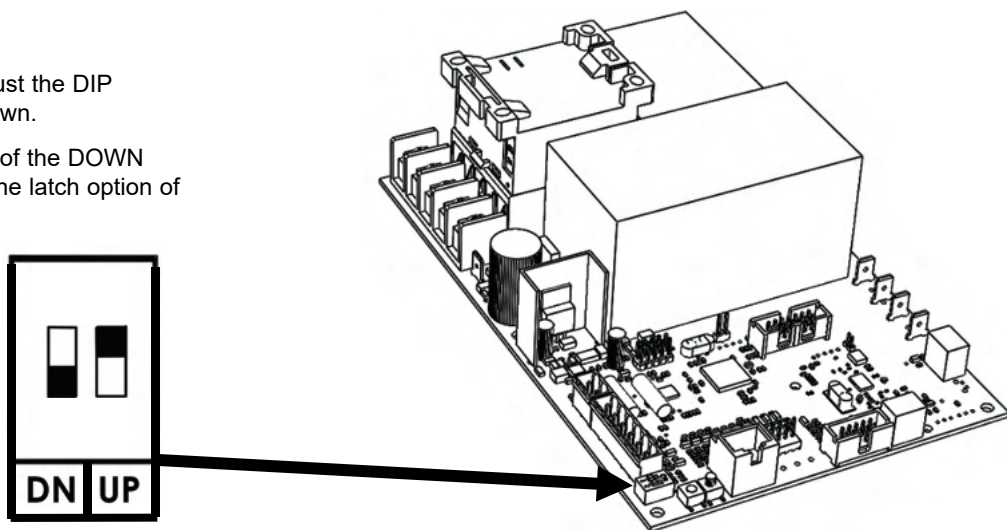

Inch Down / Latch Up (default):

The door will inch down, only travelling downwards when the DOWN button is held. The door will stop at the closed limit or when the button is released.

The door will latch up, travelling upwards with only a single press and release of the UP button. The door will stop at the set limit.

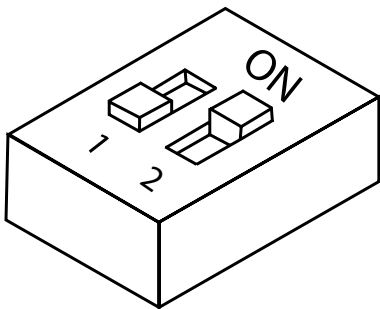

Inch Down / Inch Up:

The door will inch down and inch up, only travelling whilst the DOWN or UP buttons are being held. The door will stop at the limits or when the button is released.

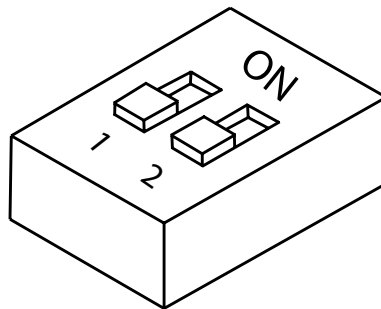

Latch Down and Latch Up*:

The door will latch down and latch up, travelling either upwards or downwards with only a single press and release of the DOWN or UP buttons respectively. This configuration must be set to enable myQ Operation.

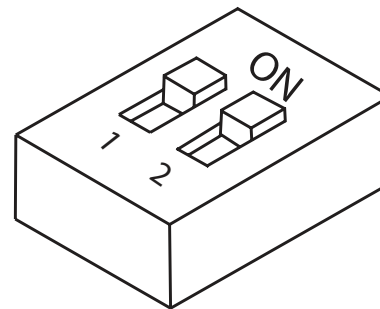

* Latch Down mode is only possible when Entrapment Protection Devices such as an Infrared Safety (IR) Beam or a Safety Bump Edge have been installed and are operating correctly. Failure to add Entrapment Protection Devices may result in damage to property or injury to persons.

NOTE: The myQ Internet Gateway can only be learned when the door behaviour mode is set to Latch up and down and the appropriate Entrapment Protection Devices have been installed and are operating correctly.



WARNING MECHANICAL

Entrapment Protection

The Entrapment Protection System for your installation will be determined by the functional requirements of the door. To ensure the installation meets these requirements refer to AS/NZS 60335-2-103.

When using the Grifco® Protector System as part of the Entrapment Protection System, ensure it is installed to detect a 100mm high obstacle, i.e.; approximately 80mm from the floor, and in accordance with installation directions supplied.

ENTRAPMENT PROTECTION AND ACCESSORIES INPUTS

Devices such as Infrared (IR) Beams and Safety Bump Edges allow safe automatic or latch closing of the door and can be wired into the MCB via an appropriate cable entry. Grifco® Entrapment Protection Devices such as the Protector System and Bump Edge are wired into the quick connect inputs located next to the door behaviour DIP switches on the MCB.

Entrapment Protection Options

IR1: Monitored Grifco® Protector System, or NC (normally closed) switching input

IR2: Monitored Grifco® Protector System, or NC (normally closed) switching input

BUMP: Monitored 8K2 Resistor type Bump Edge input.

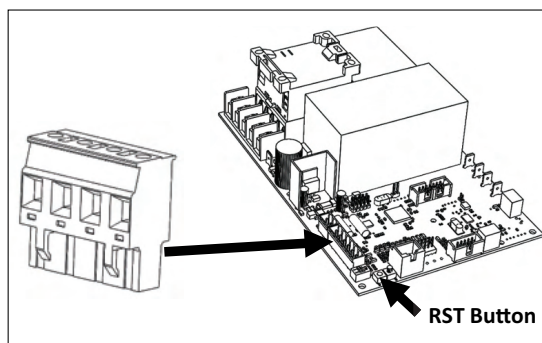

Setting Up Entrapment Protection Device

Methods used to provide safety and compliance are determined by the functional requirements of the installation and the door type. It is the responsibility of the installer to ensure the installation meets the requirements of AS/NZS 60335.2.103.

To install an Entrapment Protection Device, ensure the door is at the open limit position and then follow the instruction manual that comes with the device. All Entrapment Protection Devices and monitored Bump Edges require at least one simulated obstruction or activation to be learned by the opener. Once learned, the latch down mode will be allowed when set.

NOTE: some IR protection devices require a minimum distance of more than 1m between the sensor and reflector to function correctly.

Setting Up Entrapment Protection for When Door is Opening

IR2 can be set so that while the door is opening, and a connected IR beam is obstructed, the door will stop moving.

1. Position the door to the closed limit position.
2. While holding the SET button, press and hold the UP button for approximately 4 seconds.

The STATUS indicator will quickly flash then go out.

3. Connect a monitored Grifco Entrapment Protection Device into IR2. A N/C relay type IR switching device is not compatible.
4. Simulate an obstruction to learn the IR device.
5. Press the OPEN button, and while the door is moving, obstruct the IR device and check the door stops, reverses for 1 second, and stops.

To change IR2 to the factory default setting of sensing an obstruction while closing:

1. Position the door to the closed limit position.
2. While holding the SET button, press and hold the DOWN button for approximately 4 seconds.

The STATUS indicator will quickly flash then go out.

Erasing Entrapment Protection Devices

To erase the learnt entrapment devices from the MCB press and hold the RST button for 10 seconds or until the green LED on the MCB blinks rapidly.

Accessory Power

The E-Drive has an unregulated 24 Volt, DC output connection labelled (VDC) located near the Entrapment Protection Device inputs. Accessories connected to this output should not draw more than a maximum 150mA. For additional loads, use a separately mounted power supply.

NOTE: Grifco GPS IR beams must NOT be connected to the VDC output.

Additional Switchgear (e.g. dedicated open/close and Auto Mode etc)

The E-Drive can be easily interfaced by the reverse side of the controller push button panel. To do so you will need terminal blocks (P/N TB210) available from your local commercial door dealer or Chamberlain®.

NOTE: A controller must always be plugged in for the opener to function. When utilising the AUTO or ESTP terminals the respective bridge must be removed (refer right).

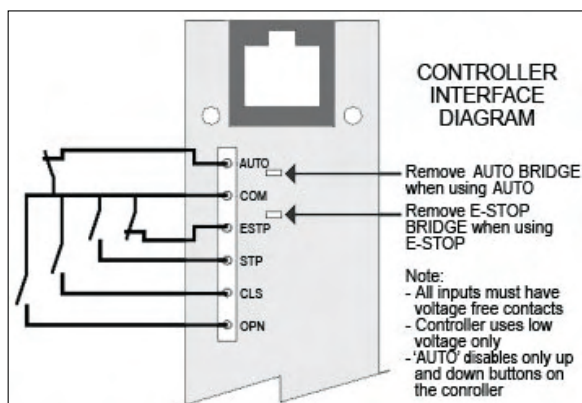

ENTRAPMENT PROTECTION AND ACCESSORIES INPUTS

Toggle Input (2 wire)

A 2 wire toggle input is provided on the MCB to allow single button (or access control) operation. The input will operate as “open-stop-close-stop-etc.”

If Auto close is set, the toggle behaviour will become “open only”.

When the toggle input is bridged* and held (e.g. a timer or latching switch) the door will remain open (i.e. Auto Close ignored). If the bridge is released, Auto Close will resume.

** If an EB is fitted, this feature will not be available on the MCB toggle input. Use EB com open input instead.*

For a typical car park configuration:

- The opener must be installed in accordance with the instructions contained within this document.
- Entrapment Protection Devices must be installed before the product can be set for Auto Close.
- For Latch Up (open) and Latch Down (close) set the dip switches on the MCB in accordance with the “Setting Door Behaviour” instructions.
- Set Auto Close in accordance with the instructions.

Access Control Options

- Grifco® Security +2.0 Transmitter or other Grifco® Security +2.0 Wireless Accessories
- Swipe Card, Magnetic Key or similar access control device

The transmitter once programmed can control entry and exit for the user. Auto Close once set, will close the door after the programmed delay on both entry and exit.

Access control devices such as swipe card, magnetic key and other similar systems must be a two wire voltage free interface and be connected to the toggle input on the MCB via the quick connect pluggable terminal block.

Transmitter Management

If transmitter management is required, you will need a Grifco® STAR1000EVO. This accessory will allow up to 1000 identified users to be individually added and deleted.

Exit Control

The door can be configured to open from either a:

- Grifco® Security+2.0 Transmitter or other Grifco® Security+2.0 Wireless Accessory device, or
- Where a loop detector or similar access controls are required to trigger opening to exit, connect to the toggle input on the MCB via a quick connect pluggable terminal block as described above.

NOTE: The Toggle Input will accept N/O inputs from multiple access control devices eg, both a separate entry and exit control.

Auto Close Feature

When Auto Close is enabled, the Toggle Input, and Receiver behaviour will become “Open Only” i.e. an activation via the Toggle Input or a Transmitter during opening, or Auto Close delay, will not close the door. Each activation will add Auto Close delay.

Advanced Logic Functionality

For applications where full logic functionality (eg relay status outputs, advanced door behaviour, building management system integration) is required please order the Grifco® EB1 Expansion Board. Contact 1800 GRIFCO® for more information.



CAUTION

Any access control intended for these terminals must be user operated and in line of sight with the door.



WARNING MECHANICAL

Keep additional accessories away from children. Do not allow children to play with pushbuttons or remote controls. Without safety devices a door can cause serious injuries as it closes. Only trained people are allowed to use the opener.

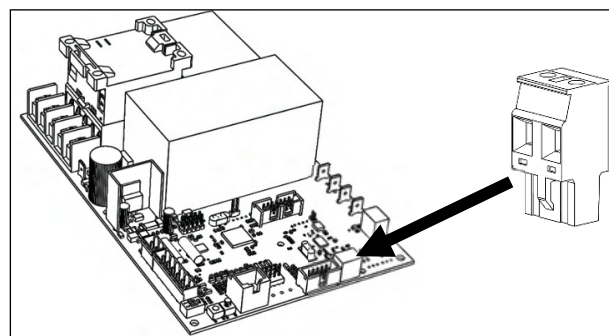

ACCESSORIES

TYPES OF ACCESS DEVICES

All Grifco remote access devices feature Security +2.0 technology. This advanced platform cuts through interference, and ensures consistent, reliable, long range operation of your commercial door.

With inbuilt perpetual rolling code technology, Grifco Security +2.0 transmitters are safe and secure. All devices feature exceptional battery life, easyconfiguration and long range.

SECURITY +2.0 REMOTE ACCESS



E960G
4-Channel Keyring Transmitter



E943G
3-Channel Visor Transmitter



E138G
2-Channel Wall Transmitter



E840G
Wireless Security Keypad



STAR1000EVO
Transmitter Management Device



GPS15
Infrared (IR) Reflective Beam





G828AU
myQ Internet Gateway

AUTO CLOSE AND WIRELESS ACCESSORY SETUP

Action	Button Sequence
<p>SET AUTO TIMER TO CLOSE (no expansion board fitted) FROM THE CONTROLLER</p>	<ul style="list-style-type: none"> • Press and hold the SET button, then whilst holding press the DOWN button 3 times (green status light ON solid) • Press the UP button to increase the auto-timer to close setting in 10-second increments • Press the DOWN button to decrease the auto-timer to close setting in 10-second increments <p>NOTE: the green light will flash according to the number of 10-second increments have been set, then goes back to solid ON. For example, a 5-minute auto-close will be set by increasing the increments until the green light flashes 30 times</p> <ul style="list-style-type: none"> • Press SET to accept setting and exit learn mode <p>NOTE: To cancel the Auto-timer-to close function, enter the learn mode and press the DOWN button until the number of 10-second increments is ZERO. The green light will flash repeatedly to indicate the function has been reset, then return to solid ON</p> <ul style="list-style-type: none"> • Press STOP to exit
<p>LEARNING A NEW WIRELESS ACCESSORY (INCLUDING MYQ GATEWAY) FROM THE CONTROLLER</p>	<p>NOTE: Radio Lock jumper (if fitted) must be removed from the MCB before wireless accessories can be learnt. For security reasons the Radio Lock should be refitted after the wireless learn sequence is completed.</p> <ul style="list-style-type: none"> • Press and hold the SET button, then whilst holding press STOP 5 times (green status light will light then continue flashing. Indicating Learn Mode) • Press the desired WIRELESS ACCESSORY BUTTON to learn (orange limit light will flash fast after each wireless accessory is successfully learnt) • Press STOP to exit Learn Mode <p>NOTE: Hand held remotes can only be learned during the first 30 seconds of Learn Mode. NOTE: For myQ, ensure both dipswitches are in the UP position and the myQ Gateway must remain powered at all times. Third party operators with disconnect switches may override myQ functionality.</p>
<p>LEARNING A NEW WIRELESS ACCESSORY (INCLUDING MYQ GATEWAY) FROM THE MCB</p>	<ul style="list-style-type: none"> • Press the LRN button (green status light will light then continue flashing, indicating Learn Mode) • Press the desired WIRELESS ACCESSORY BUTTON to learn (orange limit light will flash fast after each wireless accessory is successfully learnt) • Press LRN button again to exit Learn Mode <p>NOTE: For myQ, ensure both dipswitches are in the UP position and the myQ Gateway must remain powered at all times. Third party operators with disconnect switches may override myQ functionality.</p>
<p>ERASE ALL LEARNED WIRELESS ACCESSORIES FROM THE CONTROLLER</p>	<ul style="list-style-type: none"> • Press and hold the SET button, then whilst holding • Press the STOP button 4 times, holding on the fourth press for 5 seconds (green light will flash 5 times, then fast flash to indicate completion) • Check that previously learned wireless accessories no longer work <p>NOTE: To unlearn a myQ Internet Gateway only, while holding the SET, button press the STOP button 3 times holding on the third press for 7 seconds.</p>

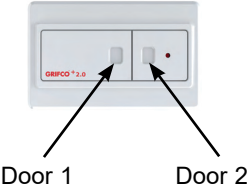
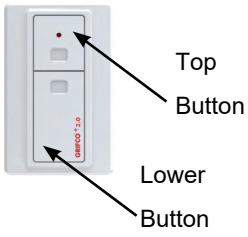
AUTO CLOSE AND WIRELESS ACCESSORY SETUP

Action	Button Sequence
<p>LEARN THE E138G WIRELESS WALL CONTROL FROM THE CONTROLLER</p> <div style="text-align: center; margin: 10px 0;">  </div> <div style="text-align: center; margin: 10px 0;">  </div>	<p>The E138G can be used as a two channel wireless wall control for use on one or two doors, or as a dedicated up/down wireless wall control. In either application for the door to latch down an Entrapment Protection Device must be installed. Without Entrapment Protection in two channel configuration the wall control will function as an open/stop device only and in dedicated up/down configuration the down button will operate as “hold to close” only.</p> <p>Two Channel Wireless Wall Control</p> <ul style="list-style-type: none"> Press and hold the SET button, then whilst holding press STOP 5 times (green status light will light then continue flashing. Indicating learn mode) Press the desired WIRELESS ACCESSORY BUTTON to learn door 1 (orange limit light will flash fast after each wireless accessory is successfully learnt) Repeat previous step to learn door 2 (if required) Press STOP to exit learn mode <p>Dedicated Up/Down Wireless Wall Control</p> <ul style="list-style-type: none"> Press and hold the SET button, then whilst holding press STOP 5 times (green status light will light then continue flashing. Indicating learn mode) Press the E138G TOP button (the orange LIMIT light will flash at each button press) Then press the E138G LOWER button Press the STOP button on the GRIFCO® controller (the green light will continue to flash) Press the E138G LOWER button again (the green light will go out indicating exit of learn mode)
<p>LEARN THE E840G WIRELESS KEYPAD FROM THE CONTROLLER</p> <div style="text-align: center; margin: 10px 0;">  </div>	<p>Press and hold the SET button on the GRIFCO® controller, then</p> <ul style="list-style-type: none"> While holding the SET button, press the STOP button 5 times (the green status light will light then continue flashing, indicating learn mode) Enter a 4-digit PIN code into the keypad (step 3) Press the ENTER button (step 4) (orange LED flickers on controller) To enter additional PIN codes (up to 12) repeat steps 3 & 4 Press STOP to exit learn mode Install the RADIO LOCK button on the MCB to prevent any further wireless accessories being learnt, or erased without authority <p>NOTE: The Grifco® Security + 2.0 Wireless Keypad provides :</p> <ul style="list-style-type: none"> Wireless security access Wireless hold to close



WARNING MECHANICAL

Power **MUST** be turned off before servicing or adjusting the opener. Disconnect the supply when cleaning!

Frequently examine the E-DRIVE installation for imbalance and signs of wear or damage to cables, springs and mounting. Do not use if repair or adjustment is necessary. Power must be turned off before servicing, cleaning or adjusting the opener.

Certain mechanical aspects of the installation must be checked at regular intervals.

Monthly

- Examine the installation for imbalance and signs of wear or damage to cables, springs and mounting. Do not use if repair or adjustment is necessary
- Check chain alignment, tension and condition. Adjust / replace if required
- Check PE / IR beam/s and bump edge functionality where applicable

Quarterly

- Check tightness of fixing bolts and (sprocket) grub screws. Adjust if required.
- Check correct electrical operation.
- Check manual operation via hand chain.
- Lubricate the drive chain.
- Check door balance. The drive chain should display a transition of tension from one side of the linkage to the other in the lower half of the roller door travel. This transition is the 'balance' point. Adjust if required.
- Conduct door maintenance in accordance with door manufactures guidelines. This will include door balance.

NOTE: SERVICE MUST BE CARRIED OUT BY A QUALIFIED TECHNICIAN

To view total cycles (limits must be set)

- Drive to door to closed limit.
- Press and hold CLOSE for 10 seconds.
- After 10 seconds and while still holding CLOSE, press and release the SET button.
- Status LED will light up indicating number of cycles performed.

To read number of cycles, follow the 'Reading Status Flashes' routine described below.

Reading Status Flashes

- STATUS indicator will start flashing to signify the value of the least significant digit of the overall number. A solidly lit indicator stands for zero.
- Press set to view the next digit.
- Continue previous step until the STATUS indicator flashes quickly for 1 second then goes out. This signifies that the entire number has been displayed.

To reset error

(This process indicates there has been a severe problem. Persistent resetting will void warranty and may damage the door and/or opener). This procedure will only work when the status light is flashing 4, 5, 9, 10, 14 or 15 times.

- Hold the STOP button for 10 seconds
- While still holding the STOP button, press and release the SET button

The STATUS indicator should flash quickly for 1 second. Any errors that were flashing should have stopped.

TROUBLESHOOTING

Status Indicator (Green) Flash / Problem Table

No. flashes/ Problem	Meaning	Possible Causes	Possible Solutions
Solid ON	Motor running		
2	Infrared beam and/or Bump edge obstruction N/C beam removed	IR beam obstructed	<ul style="list-style-type: none"> • Clear obstruction
		Bumper edge pressed	<ul style="list-style-type: none"> • Remove pressure from bump edge
		The opener has detected removal of an Entrapment Protection	<ul style="list-style-type: none"> • Set DIP 1 to OFF and press 'reset' (RST) button on MCB for 10 seconds. Re-learn any remaining Entrapment Protection Devices
3	Entrapment Protection Device removed	The opener has detected removal of an Entrapment Protection Device	<ul style="list-style-type: none"> • Set DIP 1 to OFF and press 'reset' (RST) button on MCB for 10 seconds. Relearn any remaining Entrapment Protection Devices
4	MCB error	Internal Error	<ul style="list-style-type: none"> • Power off, and on. If un-resettable replace MCB
5	EB internal error	EB disconnected or ignored from MCB	<ul style="list-style-type: none"> • Return EB to the installation or resolve EB issue, refer Elite Manual
9	APE error	APE position jump	<ul style="list-style-type: none"> • Replace APE assembly
		Severe close range frequency	<ul style="list-style-type: none"> • Press 'reset' (RST) button on MCB for 3 seconds
		APE cable disconnected APE cable fault	<ul style="list-style-type: none"> • Reconnect APE cable • Replace APE cable
10	Under speed error	Extreme load on door	<ul style="list-style-type: none"> • Check for objects causing interference to door operation • Check door installation • Check for damage to motor • Upgrade to a larger opener
12	Safety Input Error	Safety input has triggered	<ul style="list-style-type: none"> • Assess device connected to Safety Input
14	Direction error	Motor connections altered	<ul style="list-style-type: none"> • Change door direction and reset limits
15	Clutch slip (if fitted) No speed detected Contactor failure	Clutch adjustment set too low	<ul style="list-style-type: none"> • Check clutch adjustment
		Motor stalled	<ul style="list-style-type: none"> • Check door for mechanical failure or motor fault
		Extreme vibration or impact during transit	<ul style="list-style-type: none"> • Replace MCB
Constant flash	Due for service	Door is due for routine service	<ul style="list-style-type: none"> • Contact your local door dealer to arrange service
No Lights Displayed		With no lights on MCB or Controller: Power supply not correctly connected	<ul style="list-style-type: none"> • Check transformer • Check power supply wiring
		With light on at MCB: Bad connection to Controller	<ul style="list-style-type: none"> • Refer below if lights are on at MCB and not on Controller
Push button not responding	Opener does not drive up and / or down	Bad connection to Controller Damaged Controller cable Controller buttons forced and dislodged from rear of lid	<ul style="list-style-type: none"> • Check RJ45 plugs are clipped in securely at Controller and MCB • Check connections • Replace Controller cable • Replace Controller
Open or Clode button not responding but green light comes on	Coil failure or incorrect motor wiring if green light on whilst holding up or down button and opener does not move in one direction	Extreme vibration or impact during transit Incorrect motor terminal connection	<ul style="list-style-type: none"> • Replace MCB • Correctly wire the motor

TROUBLESHOOTING



WARNING ELECTRICAL

Power MUST be turned off before servicing or adjusting the opener. Disconnect the supply when cleaning!

1. No indicator lights on controller

Are there any indicator lights ON the MCB (Main Control Board)?

YES: Check connection between MCB and wall control
Check for damage to control cable.

NO: Check power supply.

2. Power light illuminated on controller but door will not go up

Does the green status light come ON when button is being pressed?

YES: Check for loose motor terminal connection. If green light begins to flash, Refer to Status Indicator (Green) Flash / Problem Table.

NO: Check for control circuit isolating switch or connection between MCB and controller.

Check for damage to control cable.

3. Power light illuminated on controller but door will not go down

Is the green status light flashing 2 or 3 times?

2 times: check for obstructions or IR beam misalignment.

3 times: check for persistent IR beam obstruction, misalignment or bump edge wiring problem.

NO: *continue onto next question.*

Check for correct wiring connection and DIP switch settings on MCB.

4. Can't set limits:

Does the orange light start flashing after the third press of the 'set' button?

YES: But green status light starts to flash 'x' times while attempting to set upper limit. Refer to Status Indicator (Green) Flash / Problem Table.

NO: Ensure all external devices and external push buttons are disconnected from wall control.

Check for damage to control cable.

5. Opener activates from controller but not remotes

Are limits set?

YES: Change remote battery. If using Expansion board check key switch position is in auto and check MCB and Expansion board DIP switches are set correctly. Check that remote is learned and receiver card is picking up signal.

NO: Set limits.

6. Opener will only travel around 200mm either way

Are limits set? i.e. orange limit light ON = limits not set.

YES: Check damaged to control cable.

NO: Set limits. If unable to set limits refer to above no. 4

7. Works from controller but automatic functions do not: (only applicable when using an Expansion Board)

Is there a solid orange (COMS) light on the Expansion Board?

YES: MCB (Main Control Board) must be reset. Call Chamberlain (1800 GRIFCO) for resetting procedure.

NO: Make sure key is in correct position.

8. Power light intermittently goes OFF and ON

Is the power light going off on the MCB also?

YES: Check supply wiring.

NO: Check connection between MCB and controller.

Limited Warranty in Australia and New Zealand

1. Your consumer rights and guarantees

This Limited Warranty is provided by Chamberlain Australia Pty Ltd. Chamberlain New Zealand Limited (Chamberlain), contact details in Section 5 below. This Limited Warranty applies to a Grifco® Commercial unit (Unit) purchased in Australia and New Zealand, and gives you benefits which are in addition to your consumer rights and remedies under the Australian Consumer Law (or corresponding New Zealand consumer protection laws).

You can find out more information about your consumer rights and guarantees which the law provides in Australia at www.accc.gov.au in New Zealand at www.consumerprotection.govt.nz. We also provide this statement as required under the Australian Consumer Law:

Our goods come with guarantees that cannot be excluded under the Australian Consumer Law. You are entitled to a replacement or refund for a major failure and for compensation for any other reasonably foreseeable loss or damage. You are also entitled to have the goods repaired or replaced if the goods fail to be of acceptable quality and the failure does not amount to a major failure.

2. What does our Limited Warranty cover?

Chamberlain warrants that, when purchased new in Australia or New Zealand, the Unit (all parts of the Unit other than globes and batteries) is free from defects in materials and workmanship (Limited Warranty) for the Limited Warranty period, subject to the terms and conditions of this Limited Warranty.

The Limited Warranty period for an E-Drive (for Accessories see below) is 6 years (72 months) from the date of installation/commissioning or when a recommended cycle count for the purchased operator has been reached (which ever comes first).

Maximum recommended cycle count limits are 20,000 cycles for Low Cycle Operators (ML6xxx) and 50,000 cycles for high Cycle Operators (MH6xxx)

The Limited Warranty period for remote controlled transmitters and accessories included with the Unit (Accessories) is 12 months from the date of purchase.

The Limited Warranty for genuine spare parts is free from defects in material and workmanship for a period of 6 months from date of purchase.

3. Limited Warranty Conditions

The following terms and conditions apply to your Limited Warranty:

Our Limited Warranty is effective from date of installation/commissioning as indicated in Section 2 above;

Proof of installation/commissioning of the Unit and door service is required;

Please also see the User Manual for the Unit available on our website, or provided at the time of purchase.

4. What is not covered

Batteries and globes are not covered under the Chamberlain Limited Warranty

Travel costs incurred by Chamberlain or its authorised dealer in either travelling to and from areas outside a capital city area. These costs will be at the purchaser's expense.

Additional access costs incurred by Chamberlain or its authorised dealer in obtaining access to premises where the Unit is not readily accessible. These costs will be at the purchaser's expense.

Our Limited Warranty covers defects as explained, and does not cover all problems and mishaps that may occur in relation to the Unit including:

- you got what you asked for but simply changed your mind, found it cheaper somewhere else, decided you did not like the purchase or had no use for it;
- you misused the Unit in any way that caused the problem;
- you knew of or were made aware of any deficiencies with the Unit before date of purchase;
- use of the Unit with controls or third party devices or software which has not been supplied, or pre-approved, by Chamberlain;
- problems relating to or residing in third party hardware, software or other items with which our product is used;
- any loss of data related to you or provided by you, or loss related to downtime associated with use of the product whether through power outage, failure of internet or wireless connectivity, network disruptions, or otherwise;
- non-compliance with the relevant instructions in the User Manual;

- tampering, neglect abuse, wear and tear, accident, electrical storm, excessive use or conditions other than normal use;
- problems with, or relating to, hardware, including but not limited to the springs, hinges, guides;
- problems caused by electrical faults or replacement of batteries or light bulbs, blown fuses, electrical surges, power surges or power strikes, fire, flood, rain, water, lightning or storms;
- water or moisture ingress that causes corrosion or electrical malfunction;
- corrosion caused by sea air if located near a waterway, beach etc: lack of proper maintenance, service or care of the Unit;
- damage caused by insects, pests or other after sale damage caused by events or accidents outside Chamberlain's reasonable control and not arising under normal and standard operating conditions.

5. Where you need help with our product

If you have a problem with the Unit or if you are concerned it may be defective, please contact our Customer Service team below:

Australia Phone toll free 1800 474 326

Address Suite G.02, City Views Business Park, 65 Epping Rd Macquarie Park NSW 2113
Email customerservice@chamberlainanz.com
Website <https://www.grifco.com.au/>

New Zealand Phone toll free 0800 653 667
 Phone 09 477 2823

Address: 17B, Arrenway Drive
 Rosedale Auckland
 0632 New Zealand
Email customerservice@chamberlainanz.com
Website <https://www.grifco.co.nz/>

As a first step, our Customer Service team will provide product support assistance to help you try to resolve the problem and in some cases, replacement parts for "do it yourself repairs". If our technical team need to see the product to determine the nature of the fault we will arrange an inspection by a trained technician, or ask that you send the product to us.

If your product was installed at your premises by an authorised dealer, please contact the installer indicated in your sales documents for prompt on-site service, or consult our Customer Service team if you need help in finding a local service technician. A service fee for on-site service may apply.

Authorisation from Chamberlain is required for warranty service under this Limited Warranty.

6. Delivery Charges

If an inspection is required in order to determine the nature of the fault please send the Unit freight paid and well packaged in accordance with our instructions. Any costs associated with transporting the Unit will be at Chamberlain's cost if the Unit has breached a statutory consumer guarantee. Repairs and replacement parts provided under this Limited Warranty are free of charge (and repaired items or replacement parts for Units found to be defective will be returned to you at our cost), and warranted by Chamberlain for the remaining portion of the original warranty period. However, if you make a claim under this Limited Warranty and this Limited Warranty does not apply, or if the law does not provide you with a statutory right or remedy as a consumer, you may be required to pay labour, assessment and/or freight costs and delivery charges to repair, replace and/or return the Unit to you.

7. How to register your product

Please register your Unit and contact details at this link <https://chamberlaingroupnz.my.site.com/GrifcoWarrantyRegistration/s/> so that we or your authorised installer can locate your details and provide you with product support assistance as quickly as possible, and keep you up to date with product updates. Registration can also be done by contacting Chamberlain Customer Service.

8. Important Reminder

All other guarantees (other than your statutory rights and guarantees as a consumer under applicable laws) are excluded to the fullest extent that we may lawfully do so. Unless the law requires us to do so, we do not accept any other liability, such as compensation for damages, injury or loss.

Last updated; 27th May 2026